

MATERIAL

Glass-fibre reinforced polyamide based (PA) technopolymer, black colour, matte finish.

STANDARD EXECUTIONS

Black-oxide steel boss, standard reamed hole, fitting to shaft by means of a supplied grub screw with hexagon socket and cup end UNI 5929-85.

- **VC.792-GXX**: for gravity indicators.
- **VC.792-PXX**: for positive drive indicators.

Rear flange with internal crown gear wheel in acetal resin based (POM) technopolymer. Black-oxide steel screw and anchor pin.

FEATURES AND APPLICATIONS

The ergonomic design enables an effective grip. The lobed shape with no cavities prevents unhealthy residues from depositing and guarantees perfect cleaning.

Particularly suitable for applications on machines and equipment whose parts must be frequently cleaned by using water jets or steam.

INDICATOR CHOICE (TO BE ORDERED SEPARATELY)

To choose the indicator see the table for possible assembly with indicators. See also "Assembly instructions" for gravity indicators type G or positive drive indicators type P.

ACCESSORIES ON REQUEST

Cover CP-XX for use without the indicator.

SPECIAL EXECUTIONS ON REQUEST

Knob with stainless steel boss.



ELESA Original design



VC.792-GXX

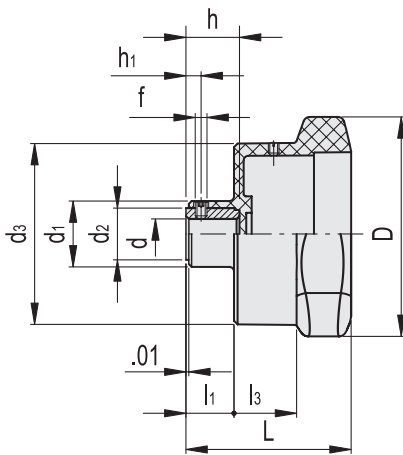

VC.792-PXX

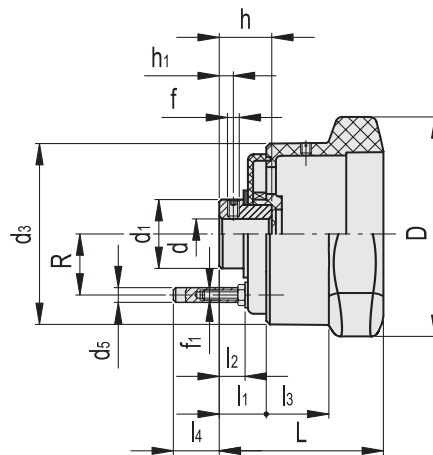

VC.792-GXX

INCH

Code	Description	D	L	d	h	d1	d2	d3	f	h1	l1	l3	⚖	Indicators combinations
CE930075	VC.792/72-GXX1 A-5/16	2.83	2.05	0.312	0.67	0.94	0.71	2.2	M5	0.24	0.63	0.75	0.17	GA01 - GA11
CE930081	VC.792/98-GXX2 A-3/8	3.86	2.28	0.375	0.87	1.08	0.87	3.01	M5	0.24	0.81	0.75	0.32	GA02 - GA12 - GW12
CE930085	VC.792/98-GXX2 A-1/2	3.86	2.28	0.500	0.87	1.08	0.87	3.01	M5	0.24	0.81	0.75	0.31	GA02 - GA12 - GW12

VC.792-PXX

INCH

Code	Description	D	L	d	h	d1	d3	d5	f	f1	h1	l1	l2	l3	l4	R	⚖	Indicators combinations
CE930072	VC.792/72-PXX1 A-5/16	2.83	2.17	0.312	0.81	0.71	2.2	0.24	M5	M4	0.2	0.73	0.41	0.75	0.57	0.75	0.19	PA01 - PA11
CE930082	VC.792/98-PXX2 A-3/8	3.86	2.28	0.375	0.87	1.18	3.01	0.24	M5	M4	0.24	0.79	0.47	0.75	0.52	1.12	0.46	PA02 - PA12 - PW12